

Tensional Sprockets

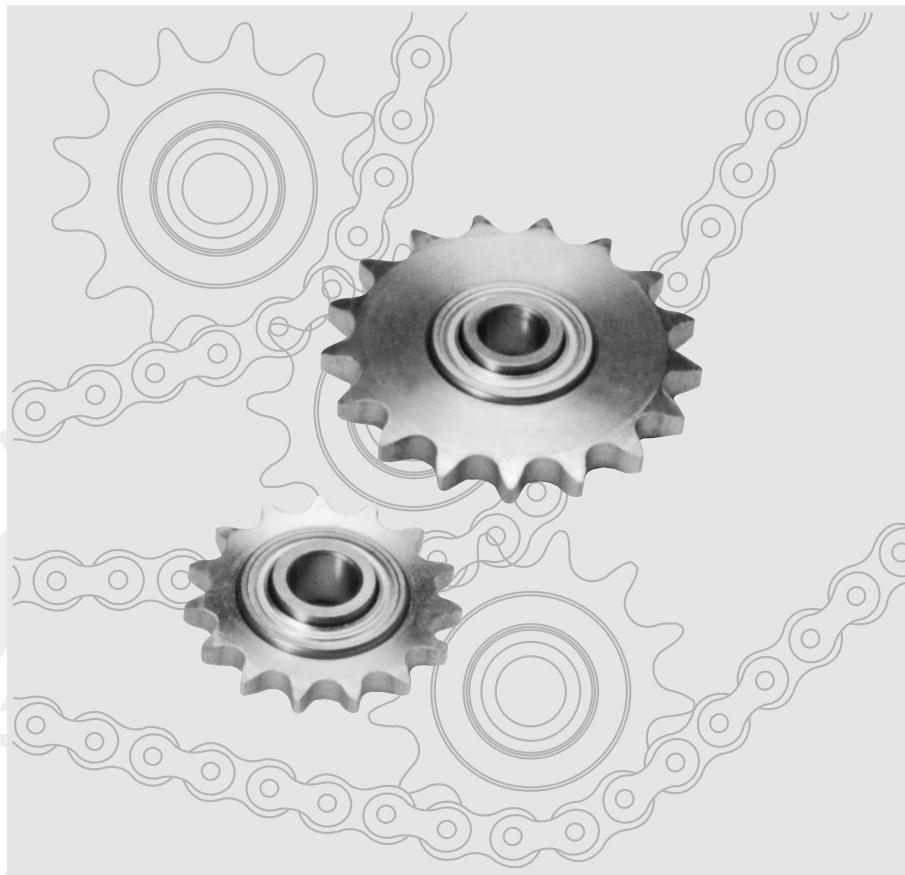
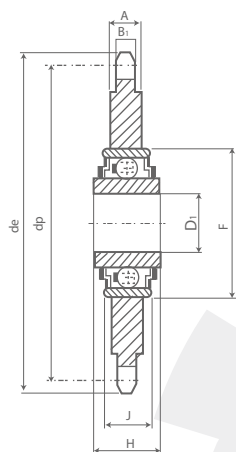

Z	PITCH	de	dp	B1	A	D1	F	H	J
23	8X1/8"	62	58.75	2.8	7	16 ^{+0.26} _{+0.13}	40	18.3	12
21	3/8"X7/32"	68	63.91	5.3	7	16 ^{+0.26} _{+0.13}	40	18.3	12
18	1/2"X1/8"	78.9	73.14	3	7	16 ^{+0.26} _{+0.13}	40	18.3	12
18	1/2"X3/16"	78.9	73.14	4.5	7	16 ^{+0.26} _{+0.13}	40	18.3	12
16	1/2"X5/16"	69.5	65.10	7.2	7.2	16 ^{+0.26} _{+0.13}	40	18.3	12
18	1/2"X5/16"	77.8	73.14	7.2	7.2	16 ^{+0.26} _{+0.13}	40	18.3	12
14	5/8"X3/8"	78.0	71.34	9.1	9.1	16 ^{+0.26} _{+0.13}	40	18.3	12
17	5/8"X3/8"	93.0	86.30	9.1	9.1	16 ^{+0.26} _{+0.13}	40	18.3	12
13	3/4"X7/16"	87.5	79.59	11.1	11.1	16 ^{+0.26} _{+0.13}	40	18.3	12
15	3/4"X7/16"	99.8	91.63	11.1	11.1	16 ^{+0.26} _{+0.13}	40	18.3	12
12	1"X17.02	109.0	98.14	16.2	16.2	20 ^{+0.26} _{+0.13}	47	17.7	14
13	1"1/4X3/4"	147.8	132.65	18.5	18.5	25 ^{+0.26} _{+0.13}	52	21	15

Tensional Sprockets

T holder

Type	Pitch	A	B
TH-B-06	P=3/8	26	47
TH-B-08	P=1/2	26	47
TH-B-10	P=5/8	26	47
TH-B-12	P=3/4	26	47
TH-B-16	P=1	30	51

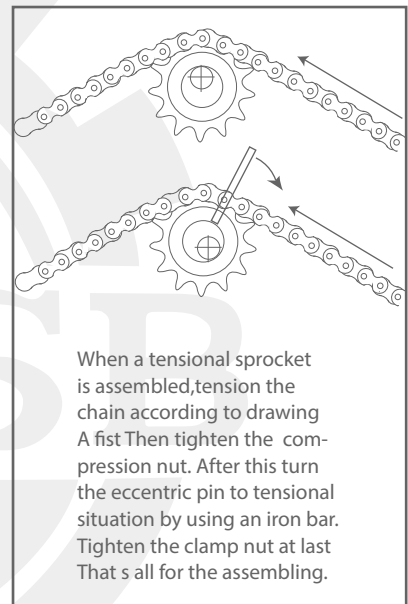
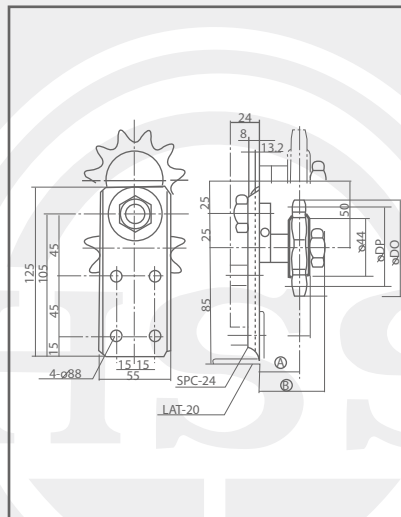
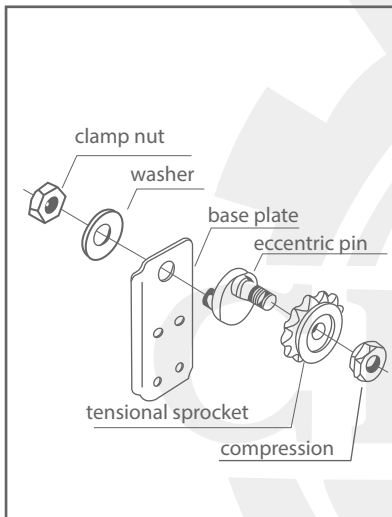

installed attachment A

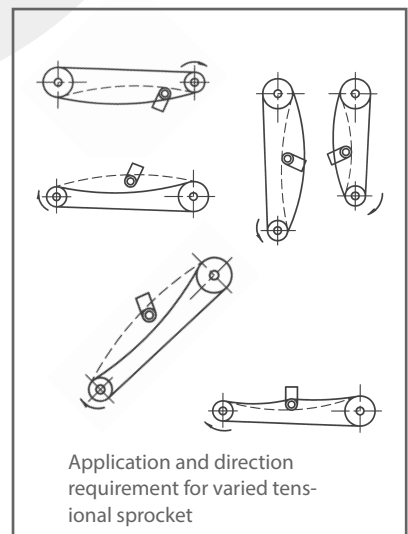
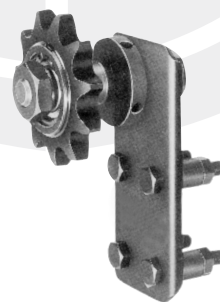
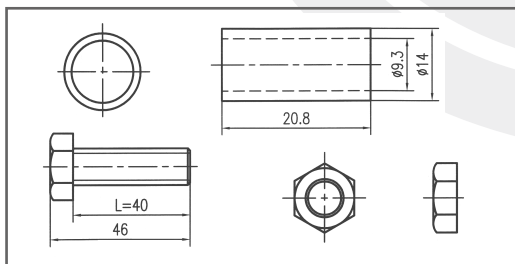

installed attachment B

